



Esco Multi-Zone ART Workstation



Design Excellence - Superior Quality

Esco Multi-Zone ART Workstation is packed with features and technology which will serve your laboratory well



table of contents

Esco Multi-Zone ART Workstation Parts and Features	4
Esco Multi-Zone ART Workstation Parts	8
General Specifications	13
Esco Multi-Zone ART with MIRI® Chambers	14
Esco Multi-Zone ART with MIRI® Chambers Parts	14
General Specifications	19
Accessories	20
Ordering Information	21
Recommended List of Microscopes and the Base Stand Types	21



Esco Multi-Zone ART Workstation



Esco Multi-Zone ART Workstation — supports superior and gentle handling of your embryos

FEATURES:

Touchscreen Monitor

The touchscreen monitor is a fully functional Windows PC with additional features:

- Displays the temperature of the heated surface, as well as the gas flow and pressure. Reports of these parameters can be generated.
- Observe and record culture behavior in real time via microscope camera function.
- Enable teleconference calls with colleagues in other sites for real time collaborative work.
(Note: Webcam is not supplied.)

Multi-Zone Heating System with Four (4) Temperature Modes

1 set point, 10 independent zones with their own heating elements and sensors allow excellent uniformity. The heating system will automatically prioritize power distribution to ensure effective temperature control with fast recovery. In models that feature MIRI® chambers, temperature regulation of the chambers will always be on regardless of mode.

- Accuracy: ± 0.2 °C
- Uniformity: ± 0.2 °C

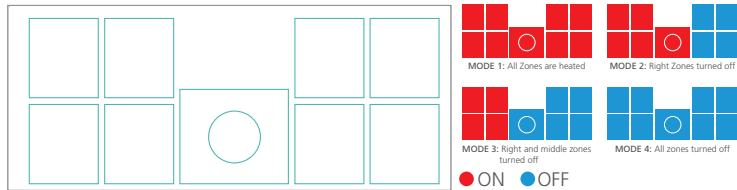

*When any of the heating zones are OFF, the monitor shall not display real-time temperature as there are no controlled heating to give uniformity across the OFF zone.

Humidification System

It allows digital control of premixed Gas which enables complete environmental control for the samples. Gas outlet port is located on the table surface and the plastic cover will enclose the humidified gas which creates small "incubator".

Non-radiating Stainless Steel Tabletop

The main material used in the tabletop surface is stainless steel. while aluminum is used for covering the bottom of the tabletop.

Heated Glass Stage

The heated glass stage has dedicated and uninterrupted power supply to further enhance the temperature control and recovery in this zone.

Microscope Integration Provision

The integrated stereoscope in the work chamber allows users to maintain culture dishes at steady temperature during observation and manipulation. Fewer movements will also reduce risk of accidents.



Advanced workstation specifically designed for Assisted Reproductive Technology (ART) such as gamete and embryo manipulation during IVF.

High-tech components and features are designed in Denmark and made in Esco's production facilities in Europe.

The workstation keeps true to Esco's world class expertise and quality in cleanroom technology.

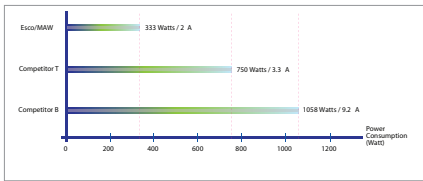

Energy Efficiency Chart

Esco ART Workstations utilize ECM blowers, allowing for low levels of cabinet power consumption without compromising cabinet performance.

It also has Standby mode that further reduces power consumption while the cabinet is not in use.

Air Cleanliness Standards (ISO 14644.1, Air Cleanliness Particle Limits) (No. of Particles / m ³)						
Particle Size (µm)	Cleanliness Class					
	Class 1	Class 2	Class 3	Class 4	Class 5	Class 6
0.1	10	100	1000	10000	100000	1000000
0.2	2	24	237	2370	23700	237000
0.3	1	10	102	1020	10200	102000
0.5	-	4	35	352	3520	35200
1.0	-	-	8	83	832	8320
5.0	-	-	-	3	29	293

Superior Air Cleanliness

Esco cabinets provide ISO Class 3 air cleanliness within the workzone as per ISO 14644.1, significantly cleaner than the conventional Class 4 classification offered by the competition.

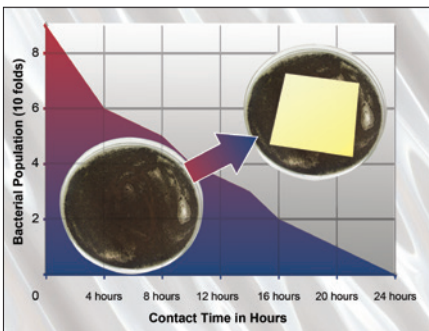

Isocide™ Powder Coat

It is a silver-ion impregnated powder coat that inhibits microbial growth to improve safety.

Esco Multi-Zone ART Workstation

- Vertical laminar airflow providing sample protection
- Low noise energy-efficient ECM blowers
- Low vibration resulting from built-in dampers
- Provision for integration of most common microscopes
- Integrated heated glass stage
- Integrated SC-1 LED Light source with dual-sided mirror and intensity control knob
- Selection of cabinet support stands
- Selection between 4ft (single) and 6ft (single, dual, MP or with MIRI® chambers) models



Less Noise, Less Vibration

Esco Multi-Zone ART Workstation has state-of-the-art design and features resulting in very low noise and vibration level that makes the workstation suitable for sensitive microscopic work.

- 2x smaller, high-efficiency ECM blower create lesser noise and vibrations than 1 big blower fan.
- Passive dampers located along the connection of the tableplate to the cabinet frame effectively dampen vibrations.

Cable Pass-Through Tunnels

The Esco Multi-Zone ART workstation has a convenient way for electrical cables of other equipment and/or accessories (i.e., a camera) to pass through its back wall. This provides a cleaner and more organized interior that should help improve your IVF workflow.

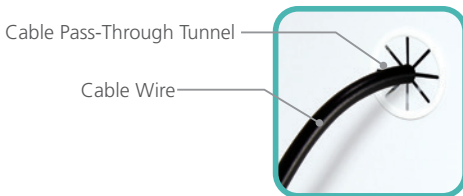

Esco Multi-Zone ART Workstation (MAW) Single Microscope

MAW-3D8

- Width: 3 Feet
- Microscope: Single
- Basic Configuration
- 1 user
- For small laboratories

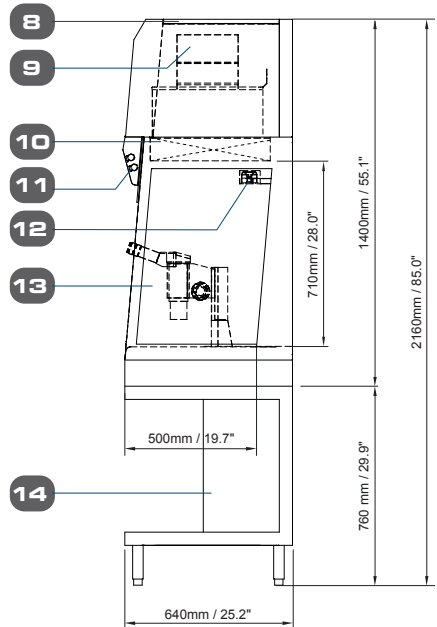
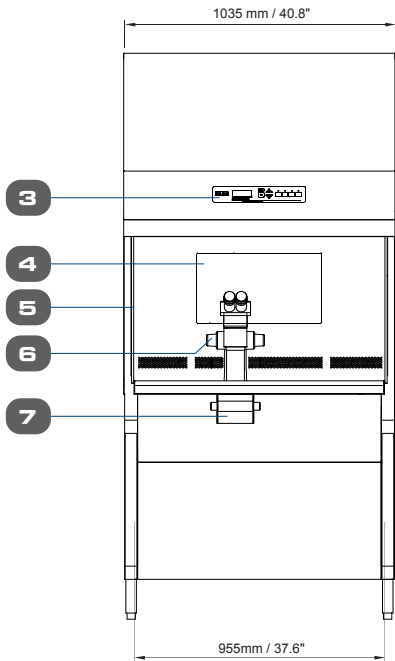
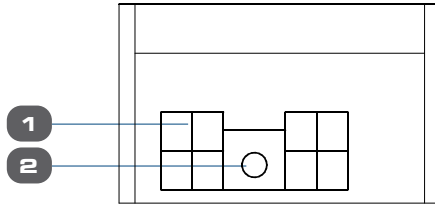

- | | | |
|--|---|------------------------------------|
| 1. Multi-Zone Heated Table Top (9+1 Zones) | 6. Provision for Microscope (Microscope not included) | 12. Airflow Sensor |
| 2. Integrated Heated Glass Stage | 7. Integrated LED Light Source, SC-1 | 13. Side Tempered Glass |
| 3. Esco Sentinel™ Gold Microprocessor Control System | 8. Pre-Filter | 14. Support Stand (Model: SML-4B0) |
| 4. Touchscreen Monitor (AIO PC) | 9. Blower | |
| 5. Side Tempered Glass | 10. ULPA Filter | |
| | 11. Fluorescent Light | |

Esco Multi-Zone ART Workstation (MAW) Single Microscope

MAW-4D

- Width: 4 Feet
- Microscope: Single
- Basic Configuration
- 1 user
- For small laboratories

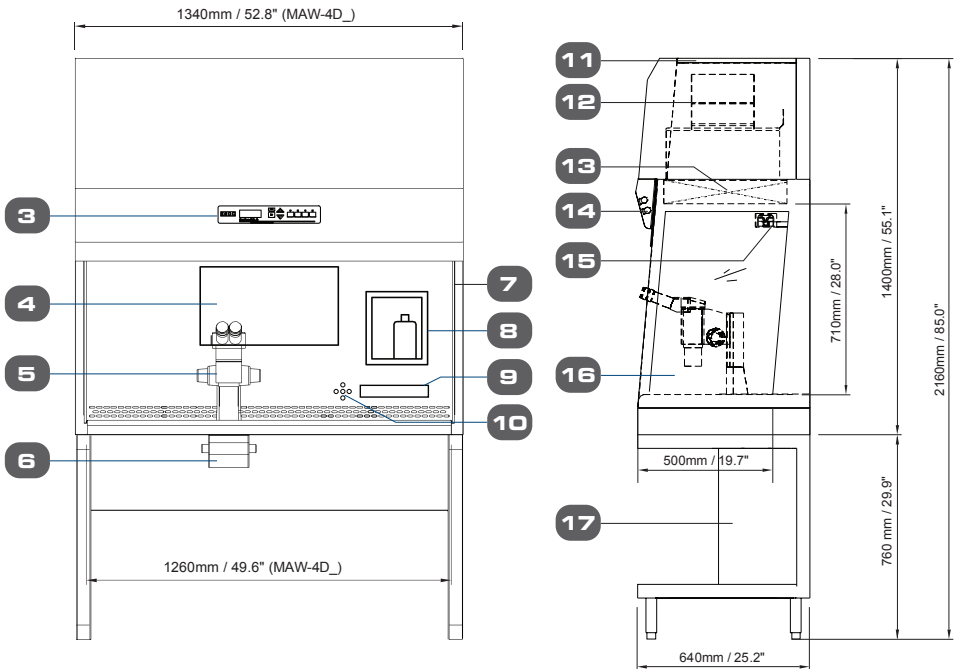
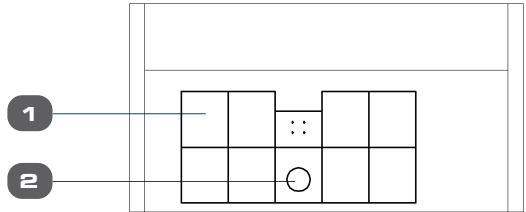

- | | | |
|---|--|------------------------------------|
| 1. Multi-Zone Heated Table Top (9+1 Zones) | 6. Integrated LED Light Source, SC-1 | 12. Blower |
| 2. Integrated Heated Glass Stage | 7. Side Tempered Glass | 13. ULPA Filter |
| 3. Esco Sentinel™ Gold Microprocessor Control System | 8. Humidification System with Digital Flow Control of Premixed Gas | 14. Fluorescent Light |
| 4. Touchscreen Monitor (AIO PC) | 9. LED Display | 15. Airflow Sensor |
| 5. Provision for Microscope (Microscope not included) | 10. Control Panel for Heated Table Top And Humidification System | 16. Side Tempered Glass |
| | 11. Pre-Filter | 17. Support Stand (Model: SML-4B0) |

Esco Multi-Zone ART Workstation (MAW) Single Microscope

MAW-6D_MONO

- Width: 6 Feet
- Microscope: Single
- Basic Configuration
- 1 user
- More space for other work

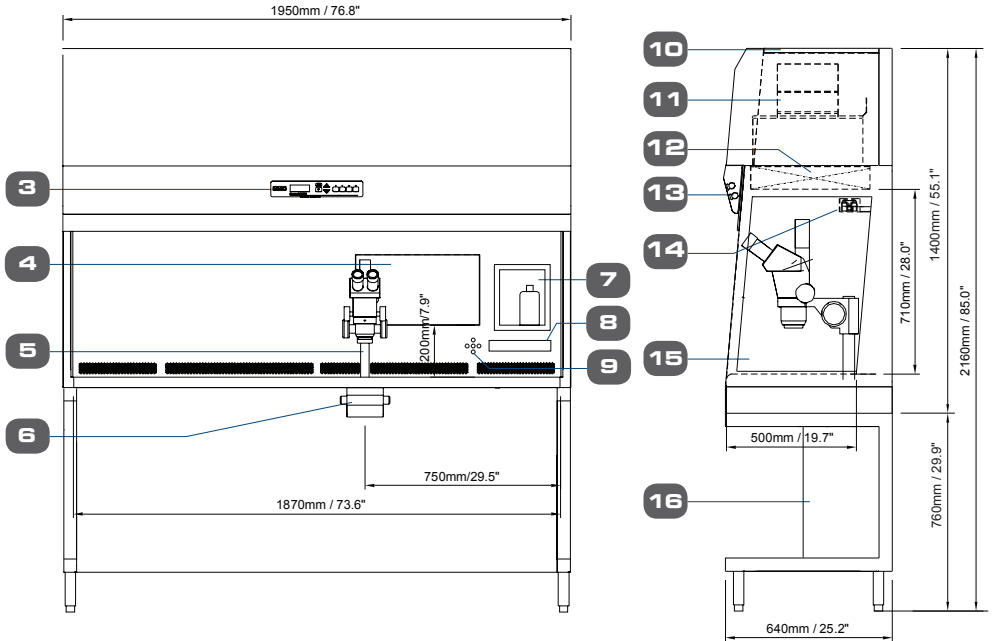
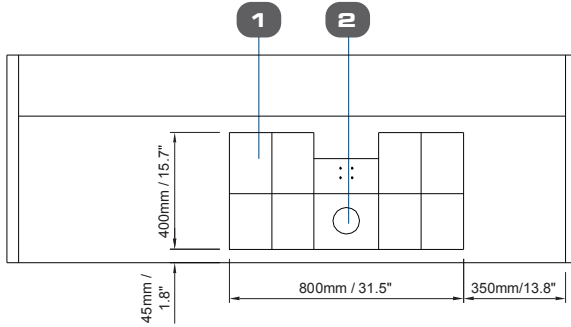

- | | | |
|---|--|------------------------------------|
| 1. Multi-Zone Heated Table Top (9+1 Zones) | 6. Integrated LED Light Source, SC-1 | 10. Pre-Filter |
| 2. Integrated Heated Glass Stage | 7. Humidification System with Digital Flow Control of Premixed Gas | 11. Blower |
| 3. Esco Sentinel™ Gold Microprocessor Control System | 8. LED Display | 12. ULPA Filter |
| 4. Touchscreen Monitor (AIO PC) | 9. Control Panel for Heated Table Top And Humidification System | 13. Fluorescent Light |
| 5. Provision for Microscope (Microscope not included) | | 14. Airflow Sensor |
| | | 15. Side Tempered Glass |
| | | 16. Support Stand (Model: SML-6B0) |

Esco Multi-Zone ART Workstation (MAW) Dual Microscope

MAW-6D_DUAL

- Width: 6 Feet
- Microscope: Dual
- 2 users
- For efficient use of space

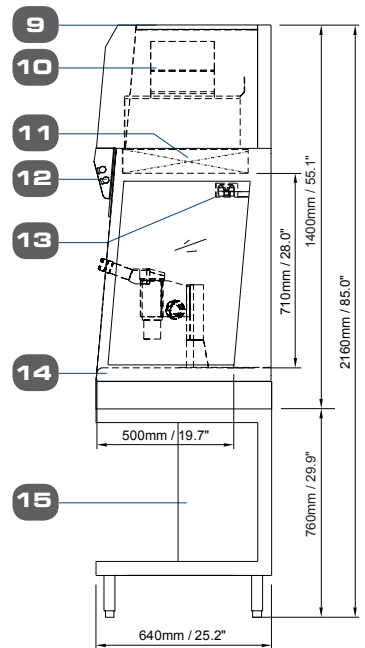
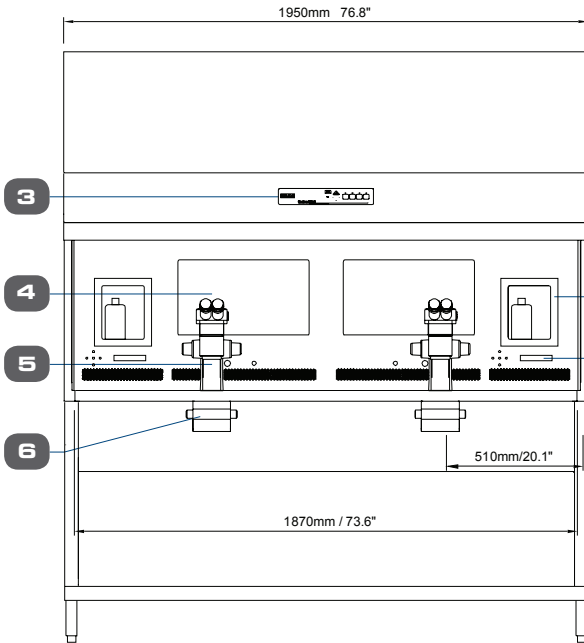
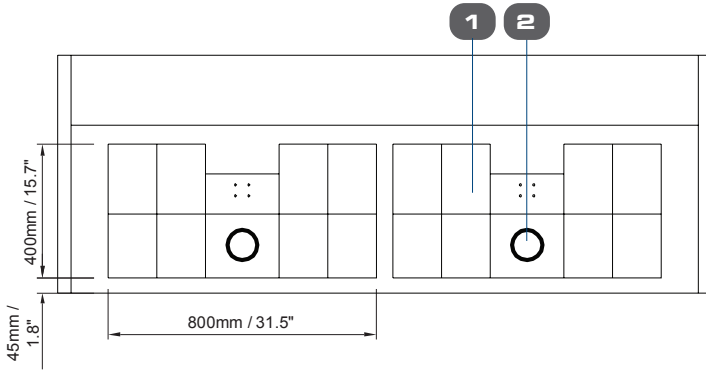

- | | | |
|---|---|------------------------------------|
| 1. Multi-Zone Heated Table Top (9+1 Zones) | 6. Integrated LED Light Source, SC-1 | 11. ULPA Filter |
| 2. Integrated Heated Glass Stage | 7. Humidification System with Digital Flow Control of Premixed Gas | 12. Fluorescent Light |
| 3. Esco Sentinel™ Gold Microprocessor Control System | 8. Display Control Panel for Heated Table Top and Humidification System | 13. Airflow Sensor |
| 4. Touchscreen Monitor (AIO PC) | 9. Pre-Filter | 14. Side Tempered Glass |
| 5. Provision for Microscope (Microscope not included) | 10. Blower | 15. Support Stand (Model: SMC-6B0) |

Esco Multi-Zone ART Workstation (MAW) Multi-Purpose

MAW-6D_-MP

- Width: 6 Feet
- Microscope: 1 Stereomicroscope,
- 1 Inverted microscope set-up
- Multi-purpose
- Embryo inspection and micromanipulation

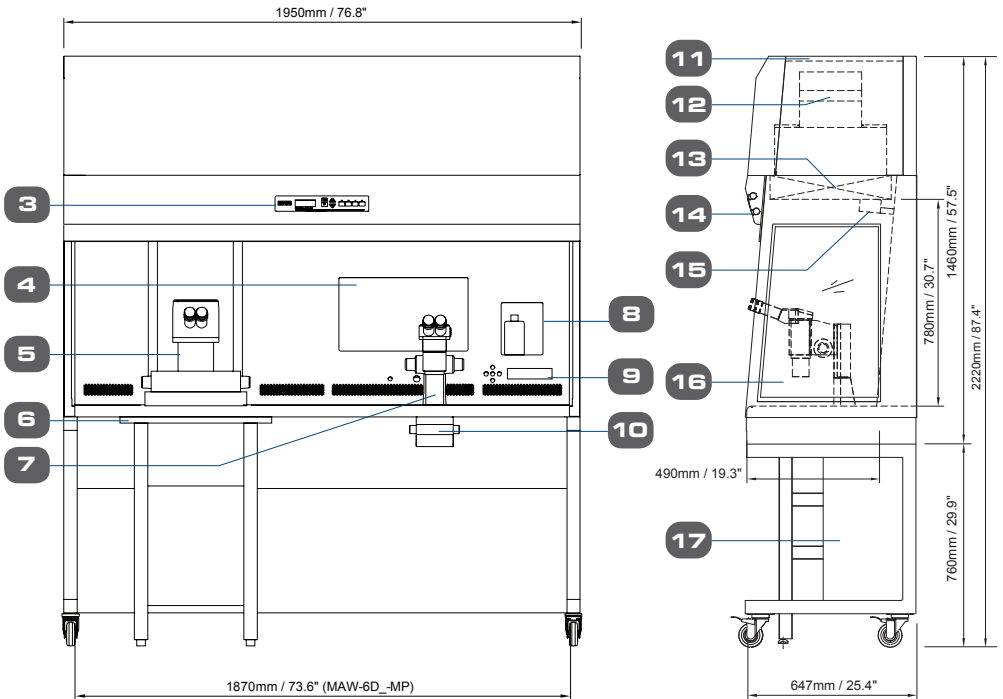
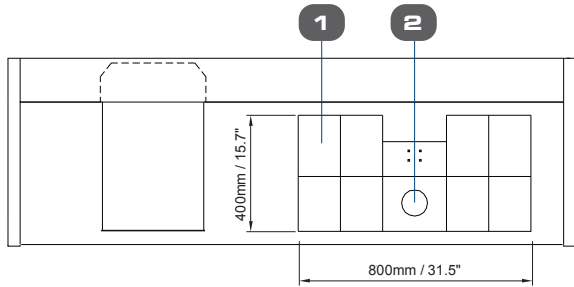

- | | | |
|---|---|------------------------------------|
| 1. Table Top (9+1 Zones) | 8. Humidification System with Digital Flow Control of Premixed gas | 13. ULPA Filter |
| 2. Integrated Heated Glass Stage | 9. Display Control Panel for Heated Table Top and Humidification System | 14. Fluorescent Light |
| 3. Esco Sentinel™ Gold Microprocessor Control System | 10. Integrated LED Light Source, SC-1 | 15. Airflow Sensor |
| 4. Touchscreen Monitor (AIO PC) | 11. Pre-Filter | 16. Side Tempered Glass |
| 5. Inverted Microscope (Not included) | 12. Blower | 17. Support Stand (Model: SPC-6B0) |
| 6. Anti-Vibration Table (AVT) | | |
| 7. Provision for Microscope (Microscope not included) | | |

General Specifications



Esco Multi-Zone ART Workstation (MAW)

Model	MAW-3D8	MAW-4D_	MAW-6D_-MONO	MAW-6D_-DUAL	MAW-6D_-MP
Nominal Size	0.9 meter (3')	1.2 meter (4')	1.8 meter (6')		
Internal Work area dimensions (width x depth x height)*	955 x 500 x 710 mm (37.6" x 19.7" x 28.0")	1260 x 500 x 710 mm (49.6" x 19.7" x 28.0")	1870 x 500 x 710 mm (73.6" x 19.7" x 28.0")		1870 x 490 x 780 mm (76.8" x 19.3" x 30.7")
External dimensions without support stand (width x depth x height)	1035 x 640 x 1400 mm (40.8" x 25.2" x 55.1")	1340 x 640 x 1400 mm (52.8" x 25.2" x 55.1")	1950 x 640 x 1400 mm (76.8" x 25.2" x 55.1")		1950 x 647 x 1460 mm (76.8" x 25.4" x 57.5")
External Dimensions with "B" type support stand (width x depth x height)	1035 x 640 x 2160 mm (40.8" x 25.2" x 85")	1340 x 640 x 2160 mm (52.8" x 25.2" x 85.0")	1950 x 640 x 2160 mm (76.8" x 25.2" x 85.0")		1950 x 647 x 2220 mm (76.8" x 25.4" x 87.4")
Cabinet Construction	Main Body	1.2 mm (0.05") 18 gauge electro-galvanized steel with white oven-baked epoxy-polyester powder coated finish			
	Work Zone	1.5 mm (0.6") gauge 16 stainless steel, grade 304	1.2 mm (0.05") 18 gauge stainless steel, grade 304		
	Side Walls	Tempered Glass (Optional: Polycarbonate sash for MAW with built-in UV light)			
	Sash				
Laminar air velocity	Average of 0.21m/s or 41 fpm (± 20%)				
Filter efficiency	>99.999% for particle size between 0.1 to 0.3 microns per IEST-RP-CC001.3 / H14 per EN 1822				
Pre-filter	Disposable and non-washable polyester fibers with 85% arrestance / EU3 rated				
Noise level (per NSF 49)**	<48 dBA	47 dBA	52 dBA		
Set of (9+1) heating zones	1 set	1 set	1 set	2 sets	1 set
Surveillance System with data logger	1 set	1 set	1 set	2 sets	1 set
Humidification System***	1 set	1 set	1 set	2 sets	1 set
PT 1000 ports	5 ports	5 ports	5 ports	10 ports	5 ports
Microscope	Required Not included (see microscope ordering information)				
	Position for 1 microscope			Position for 2 microscopes	Position for 1 microscope and 1 inverted microscope
Transmitted light source	1 set	1 set	1 set	2 sets	1 set
Support stand	Required, Not included (see support stand ordering information)				
Shipping dimensions (width x depth x height)	1120 X 820 X 1920 mm (44.1" x 32.3" x 75.6")	1450 x 850 x 1920 mm (57.1" x 33.5" x 75.6")	2050 x 850 x 1890 mm (80.8" x 33.5" x 74.4")		
Shipping weight	195 kg	280 kg	372 kg		

* The actual MAW-6D_-MP's work area dimension will be customized to fit the inverted microscope.

** Noise reading in open field condition / anechoic chamber. Noise reading in normal room varies by room size, layout, and background noise, but may reach roughly 3-4 dBA above these values.

***1 set of humidification system includes one (1) water bottle with tubing, one (1) sample carry tray and one (1) plastic cover.

Indication for Use Statement

The Esco Multi-Zone ART Workstation is a laminar flow workstation with controlled temperature and humidity working environment. The workstation is intended for working with gametes and / or embryos at / or near body temperature in a Multi-Zone heated set up during in vitro fertilization (IVF) / assisted reproductive technology (ART) treatments.



Caution

- Federal law restricts this device to sale by or on the order of a licensed healthcare practitioner.
- Only to be used by a trained and qualified professional. The device is sold under exemption specified in 21 CFR 801 Subpart D.

Esco Multi-Zone ART Workstation with MIRI® Chambers



The Esco Multi-Zone ART Workstation is now even better with its integrated MIRI® chambers to further secure your embryos while inside the workstation. The MIRI® incubator is popular for its top-notch features such as stable culture environment and faster parameter recovery.



Multi-Zone Heating System

1 set point, 8 (7+1) independent zones with their own heating elements and sensors.



MIRI® Chambers

Your specimens are more secured than ever with the integrated MIRI® chambers, known for its stable and precise temperature output.



UV Kit (Optional)

Optional UV lamp for work zone decontamination. It also comes with polycarbonate front cover for UV shield and magnetic interlock for safety mechanism when cover is removed.

Support Stand Options

More options to choose from to meet your requirements. Please see page 18.

Fit in the same MIRI® Inserts



Nunc™



Falcon®



Vitrolife



LifeGlobal®
GPS Dishes



Nipro™



SparMED Oosafe®

Accessories



- Support Stand:**
- With leveling feet
 - With Caster Wheels
 - Motorized stand with Caster Wheels



UV Kit

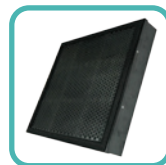

Carbon Filter

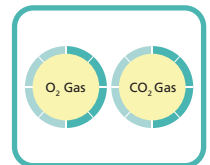

Gas Mixer for MAW

Esco Multi-Zone ART Workstation (MAW) Single Microscope with MIRI® Chambers

MAW-4D_MC

- Width: 4 Feet
- Microscope: Single
- Basic Configuration with 2 MIRI® Chambers
- 1 user
- For small Laboratories

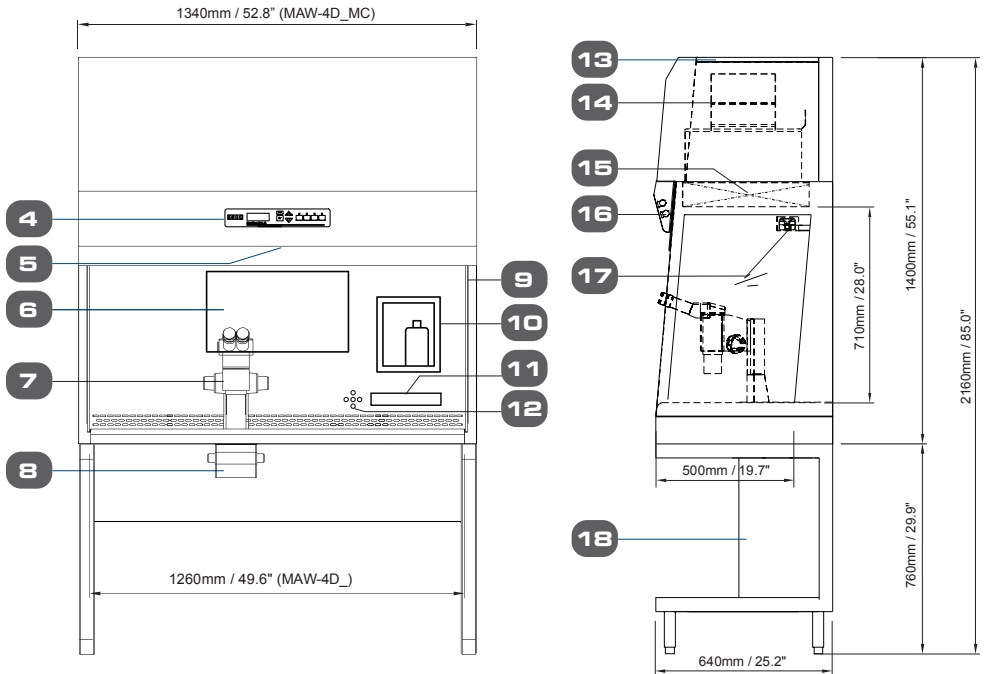
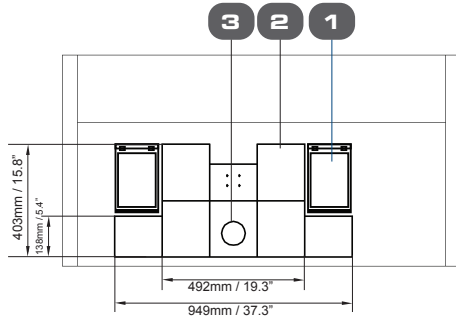

- | | | |
|---|---|------------------------------------|
| 1. MIRI® Chamber | 8. Integrated LED Light Source, SC-1 | 15. ULPA Filter |
| 2. Multi-Zone Heated Table Top | 9. Side Tempered Glass | 16. Fluorescent Light |
| 3. Integrated Heated Glass Stage | 10. Humidification System with Digital Flow Control of Premixed Gas | 17. Airflow Sensor |
| 4. Esco Sentinel™ Gold Microprocessor Control System | 11. LED Display | 18. Support Stand (Model: SML-4B0) |
| 5. UV light (optional accessory) | 12. Control Panel for Heated Table Top And Humidification System | |
| 6. Touchscreen Monitor (AIO PC) | | |
| 7. Provision for Microscope (Microscope not included) | 13. Pre-filter | |
| | 14. Blower | |

Esco Multi-Zone ART Workstation (MAW) Single Microscope with MIRI® Chambers

MAW-6D_MONO-MC

- Width: 6Ft
- Microscope: Single
- Basic Configuration with 2 MIRI® Chambers
- 1 User
- More space for other work

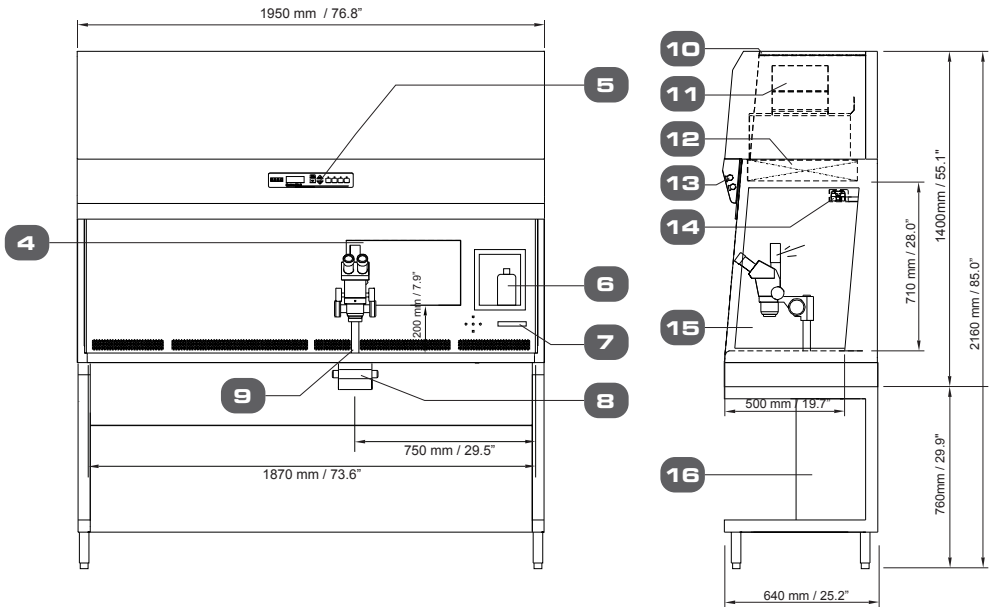
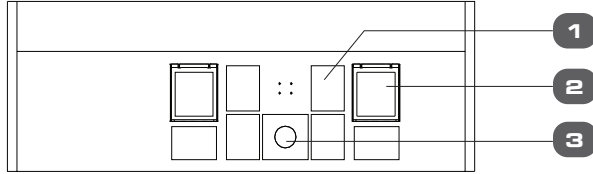

- | | | |
|--|---|------------------------------------|
| 1. Multi-Zone Heated Table Top | 7. Display Control Panel for Heated Table Top and Humidification System | 12. ULPA Filter |
| 2. MIRI® Chamber | 8. Integrated LED Light Source, SC-1 | 13. Fluorescent Light |
| 3. Integrated Heated Glass Stage | 9. Provision for Microscope (Microscope not included) | 14. Airflow Sensor |
| 4. Touchscreen Monitor (AIO PC) | | 15. Side Tempered Glass |
| 5. Esco Sentinel™ Gold Microprocessor Control System | | 16. Support Stand (Model: SML-6B0) |
| 6. Humidification System with Digital Flow Control of Premixed Gas | 10. Pre-Filter | |
| | 11. Blower | |

Esco Multi-Zone ART Workstation (MAW) Dual Microscope with MIRI® Chambers

MAW-6D_DUAL-MC

- Width: 6Ft
- Microscope: Dual
- 2 Users
- For efficient use of space

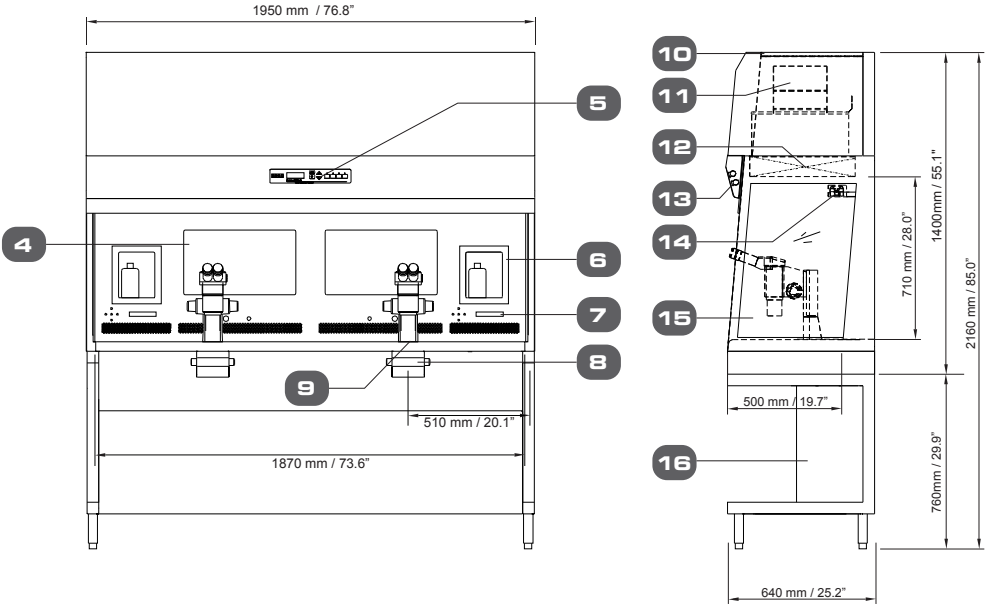
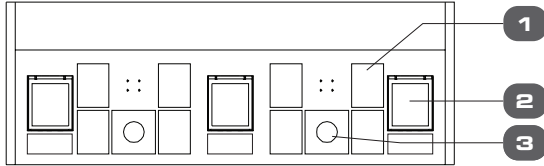

- | | | |
|--|---|------------------------------------|
| 1. Multi-Zone Heated Table Top | 7. Display Control Panel for Heated Table Top and Humidification System | 12. ULPA Filter |
| 2. MIRI® Chamber | 8. Integrated LED Light Source, SC-1 | 13. Fluorescent Light |
| 3. Integrated Heated Glass Stage | 9. Provision for Microscope (Microscope not included) | 14. Airflow Sensor |
| 4. Touchscreen Monitor (AIO PC) | 10. Pre-Filter | 15. Side Tempered Glass |
| 5. Esco Sentinel™ Gold Microprocessor Control System | 11. Blower | 16. Support Stand (Model: SML-6B0) |
| 6. Humidification System with Digital Flow Control of Premixed Gas | | |

Esco Multi-Zone ART Workstation (MAW) MP with MIRI® Chambers

MAW-6D_MP-MC

- Width: 6 Feet
- Microscope: Single
- Multi-purpose
- Embryo inspection & micromanipulation

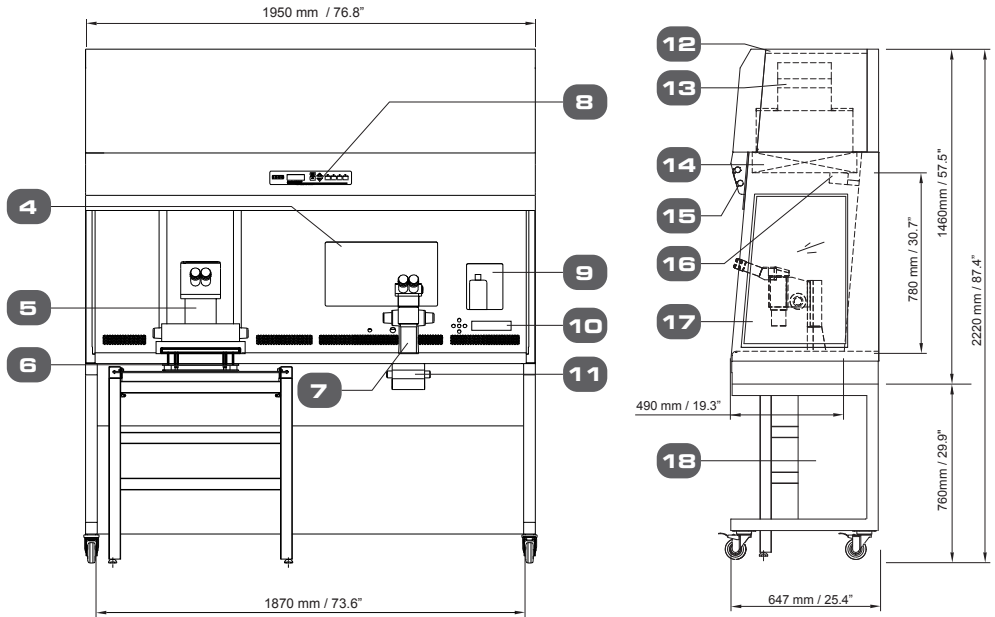
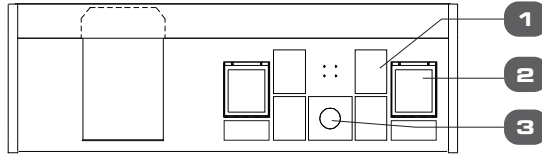

- | | | |
|---|--|-----------------------------|
| 1. Multi-Zone Heated Table Top | 9. Humidification System with Digital Flow Control of Premixed Gas | 15. Fluorescent Light |
| 2. MIRI® Chamber | 10. Display Control Panel for Heated Table Top and Humidification System | 16. Airflow Sensor |
| 3. Integrated Heated Glass Stage | 11. Integrated LED Light Source, SC-1 | 17. Side Tempered Glass |
| 4. Touchscreen Monitor (AIO PC) | 12. Pre-Filter | 18. Support Stand (SPC-6B0) |
| 5. Inverted Microscope (Not Included) | 13. Blower | |
| 6. Anti-Vibration Table (AVT) | 14. ULPA Filter | |
| 7. Provision for Microscope (Microscope not included) | | |
| 8. Esco Sentinel™ Gold Microprocessor Control System | | |

General Specifications



Esco Multi-Zone ART Workstation (MAW) with MIRI® Chambers

Model	MAW-4D_-MC	MAW-6D_-MONO-MC	MAW6D_-DUAL-MC	MAW-6D_-MP-MC
Nominal Size	1.2 meter (4')	1.8 meter (6')	1.8 meter (6')	1.8 meter (6')
Internal Work Area, Dimensions (W x D x H)	1260 x 500 x 710 mm (49.6" x 19.7" x 28.0")	1870 x 500 x 710 mm (73.6" x 19.7" x 28.0")	1870 x 500 x 710 mm (83.6" x 19.7" x 28.0")	1870 x 490 x 780 mm (73.6" x 19.3" x 30.7")
External dimensions without support stand (W x D x H)	1340 x 640 x 1400 mm (52.8" x 25.2" x 55.1")	1950 x 640 x 1400 mm (76.8" x 25.2" x 55.1")	1950 x 640 x 1400 mm (76.8" x 25.2" x 55.1")	1950 x 647 x 1460 mm (76.8" x 25.4" x 57.5")
External Dimensions with "B" type support stand (W x D x H)	1340 x 640 x 2160 mm (52.8" x 25.2" x 85.0")	1340 x 640 x 2160 mm (52.8" x 25.2" x 85.0")	1950 x 640 x 2160 mm (76.8" x 25.2" x 85.0")	1950 x 647 x 2220 mm (76.8" x 25.4" x 87.4")
Cabinet Construction	Main Body	1.2 mm (0.05") 18 gauge electro-galvanized steel with white oven-baked epoxy-polyester powder-coated finish.		
	Work Zone	1.2 mm (0.05") 18 gauge stainless steel, grade 304		
	Side Walls	Tempered Laminated Glass (Optional: Polycarbonate sash for MAW with built-in UV light)		
	Sash			
Laminar air velocity	Average of 0.21m/s or 41 fpm (± 20%)			
ULPA Filter efficiency	>99.999% for particle size between 0.1 to 0.3 microns per IEST-RP-CC001.3 / H14 per EN 1822			
Pre-Filter	Disposable, non-washable polyester fibre, 85% arrestance, EU3 rated			
Set of (7+1) heating zones	1	1	2	1
Number of MIRI® Chambers	2	2	3	2
Included accessories	1 x water bottle for HS-1, including tubing 2 x sample carry tray	1 x water bottle for HS-1, including tubing 2 x sample carry tray	2 x water bottle for HS-1, including tubing 3 x sample carry tray	1 x water bottle for HS-1, including tubing 2 x sample carry tray
Microscope	Required, Not included (see microscope ordering information)			
	Position for 1 microscope	Position for 1 microscope	Position for 2 microscopes	Position for 1 microscope and 1 inverted microscope
Support stand	Required, Not included (see support stand ordering information)			

* 1 set of humidification system includes one (1) water bottle with tubing and one (1) sample carry tray.



Accessories

ITEM CODE	MODEL CODE	DESCRIPTION
5131413	SMC-3A0	Support Stand with Caster Wheels (Height 24") for 3ft Cabinets
5131414	SMC-3B0	Support Stand with Caster Wheels (Height 30") for 3ft Cabinets
5131415	SML-3A0	Support Stand with Leveling Feet (Height 24") for 3ft Cabinets
5131416	SML-3B0	Support Stand with Leveling Feet (Height 30") for 3ft Cabinets
5131417	SMTC-3A0	S/Stand Telescopic 3ft MAW, adjustable height
5171026	FC-MAW3-8	UV+Front Cover with magnetic interlock and bracket, MAW-3FT, 230V 50/60 Hz 5170799
5130179	SMC-4A0	Support Stand with Caster Wheels (Height 24") for 4ft Cabinets
5130180	SMC-6A0	Support Stand with Caster Wheels (Height 24") for 6ft Cabinets
5130181	SML-4A0	Support Stand with Leveling Feet (Height 24") for 4ft Cabinets
5130182	SML-6A0	Support Stand with Leveling Feet (Height 24") for 6ft Cabinets
5130183	SMC-4B0	Support Stand with Caster Wheels (Height 30") for 4ft Cabinets
5130184	SMC-6B0	Support Stand with Caster Wheels (Height 30") for 6ft Cabinets
5130185	SML-4B0	Support Stand with Leveling Feet (Height 30") for 4ft Cabinets
5130186	SML-6B0	Support Stand with Leveling Feet (Height 30") for 6ft Cabinets
5131255	SMC-4A8-M	Motorized Support Stand for 4ft Cabinet, Caster Wheels, Adjustable Height: 753mm to 1053mm, 230VAC 50/60Hz
5131266	SMC-4A9-M	Motorized Support Stand for 4ft Cabinet, Caster Wheels, Adjustable Height: 753mm to 1053mm, 115VAC 50/60Hz
5131264	SMC-6A8-M	Motorized Support Stand for 6ft Cabinet, Caster Wheels, Adjustable Height: 753mm to 1053mm, 230VAC 50/60Hz
5131267	SMC-6A9-M	Motorized Support Stand for 6ft Cabinet, Caster Wheels, Adjustable Height: 753mm to 1053mm, 115VAC 50/60Hz
1320075	MAW-WB1	Tube Warming Block
1320071	MAW-MS1	Stereomicroscope, Total magnification: 6.7X - 45X
5080185	MAW-CF	Carbon Filter (568 x 440 x 30 mm). Factory-Installed. Please order 2 units for 4 feet MAW and 3 units for 6 feet MAW
5090009	PF-MAW-2	Pre-Filter, 500 x 400 Polyester Media, PF-2
5090001	PF-MAW-12	Pre-Filter, 565 x 500, Polyester Media, PF-12
5170798	FC-MAW4-8	UV+Front Cover with magnetic interlock and bracket, MAW-4FT, 230V 50/60 Hz
5170799	FC-MAW6-8	UV+Front Cover with magnetic interlock and bracket, MAW-6FT, 230V 50/60 Hz
5170853	FC-MAW4-9	UV+Front Cover with magnetic interlock and bracket, MAW-4FT, 115V 50/60 Hz
5170854	FC-MAW6-9	UV+Front Cover with magnetic interlock and bracket, MAW-6FT, 115V 50/60 Hz
5170882	MAW-G	CO ₂ /N ₂ Gas Mixer (CO ₂ /O ₂ Gas mixing control in MAW). One (1) mixer needed for each MAW
5074858	MAW-PF	MAW-4/6 Pre-filter, 565 x 440, with plate for MAW-4/6 Standard

Ordering Information



ITEM CODE	MODEL CODE	DESCRIPTION
Esco Multi-Zone ART Workstation Basic Configuration and Multi-Purpose		
2070177	MAW-3D8	Esco Multi-Zone ART Workstation, 3ft 3ft (0.91m), 230V 50/60Hz
2070017	MAW-4D8	Esco Multi-Zone ART Workstation, 4ft (1.2m), 230V 50/60Hz
2070025	MAW-4D9	Esco Multi-Zone ART Workstation, 4ft (1.2m), 115V 50/60Hz
2070018	MAW-6D8-MONO	Esco Multi-Zone ART Workstation, 6ft (1.8m), 230V 50/60Hz
2070026	MAW-6D9-MONO	Esco Multi-Zone ART Workstation, 6ft (1.8m), 115V 50/60Hz
2070050	MAW-6D8-DUAL	Esco Multi-Zone ART Workstation, Double Heated Zone, 6ft (1.8m), 230V 50/60Hz
2070039	MAW-6D9-DUAL	Esco Multi-Zone ART Workstation, Double Heated Zone, 6ft (1.8m), 115V 50/60Hz
2070036	MAW-6D8-MP	Esco Multi-Zone ART Workstation, Multi-Purpose, 6ft (1.8m), 230V 50/60Hz
2070038	MAW-6D9-MP	Esco Multi-Zone ART Workstation, Multi-Purpose, 6ft (1.8m), 115V 50/60Hz
Esco ART Workstation with MIRI® Chambers		
2070068	MAW-4D8-MC	Esco Multi-Zone ART Workstation, MIRI® Chambers, 4ft (1.2m), 230V 50/60Hz
2070070	MAW-4D9-MC	Esco Multi-Zone ART Workstation, MIRI® Chambers, 4ft (1.2m), 115V 50/60Hz
2070069	MAW-6D8-MONO-MC	Esco Multi-Zone ART Workstation, MIRI® Chambers, 6ft (1.8m), 230V 50/60Hz
2070071	MAW-6D9-MONO-MC	Esco Multi-Zone ART Workstation, MIRI® Chambers, 6ft (1.8m), 115V 50/60Hz
2070075	MAW-6D8-DUAL-MC	Esco Multi-Zone ART Workstation, Double Heated Zone, MIRI® Chambers, 6ft (1.8m), 230V 50/60Hz
2070074	MAW-6D9-DUAL-MC	Esco Multi-Zone ART Workstation, Double Heated Zone, MIRI® Chambers, 6ft (1.8m), 115V 50/60Hz
2070072	MAW-6D8-MP-MC	Esco Multi-Zone ART Workstation, Multi-Purpose, MIRI® Chambers, 6ft (1.8m), 230V 50/60Hz
2070073	MAW-6D9-MP-MC	Esco Multi-Zone ART Workstation, Multi-Purpose, MIRI® Chambers, 6ft (1.8m), 115V 50/60Hz
ART Workstation with MIRI® Chambers and Trigas Mixer		
2070187	MAW-4D8-MC-G	Esco Multi-Zone ART Workstation, MIRI® Chambers, Gas Mixer, 4ft (1.2m), 230V 50/60Hz
2070188	MAW-4D9-MC-G	Esco Multi-Zone ART Workstation, MIRI® Chambers, Gas Mixer, 4ft (1.2m), 115V 50/60Hz
2070189	MAW-6D8-MONO-MC-G	Esco Multi-Zone ART Workstation, MIRI® Chambers, Gas Mixer, 6ft (1.8m), 230V 50/60Hz
2070190	MAW-6D9-MONO-MC-G	Esco Multi-Zone ART Workstation, MIRI® Chambers, Gas Mixer, 6ft (1.8m), 115V 50/60Hz
2070191	MAW-6D8-DUAL-MC-G	Esco Multi-Zone ART Workstation, Double Heated Zone, MIRI® Chambers, Gas Mixer, 6ft (1.8m), 230V 50/60Hz
2070192	MAW-6D9-DUAL-MC-G	Esco Multi-Zone ART Workstation, Double Heated Zone, MIRI® Chambers, Gas Mixer, 6ft (1.8m), 115V 50/60Hz
2070193	MAW-6D8-MP-MC-G	Esco Multi-Zone ART Workstation, Multi-Purpose, MIRI® Chambers, Gas Mixer, 6ft (1.8m), 230V 50/60Hz
2070194	MAW-6D9-MP-MC-G	Esco Multi-Zone ART Workstation, Multi-Purpose, MIRI® Chambers, Gas Mixer, 6ft (1.8m), 115V 50/60Hz

Recommended List of Microscopes and the Base Stand Types

INVERTED MICROSCOPE FOR MP SERIES WORKSTATION ONLY
Olympus IX83P1ZF: One-Deck
Olympus IX73P1F: One-Deck (Customization on workstation needed)
Olympus IX73P2F: Two-Decks
Olympus IX53P1F: One-Deck (Customization on workstation needed)
Nikon Ti-U
Nikon Ti-S
Nikon Ti-E
Zeiss Axio Vert.A1
Zeiss Axio Vert.A1 FL
Zeiss Axio vert.A1 FL-LED

STEREOMICROSCOPE PROVISIONS	
MICROSCOPE TYPES	BASE STAND
Esco Stereomicroscope MS-1	Standard
Nikon SMZ series	C-PS / C-PS160 / C-DSS
Olympus SZX series	SZX-ST / SZX2-ST/SZ2-ST
Carl Zeiss	Stand N / V8 with T-pillar
Leica	S8AP0

ESCO LIFESCIENCES GROUP

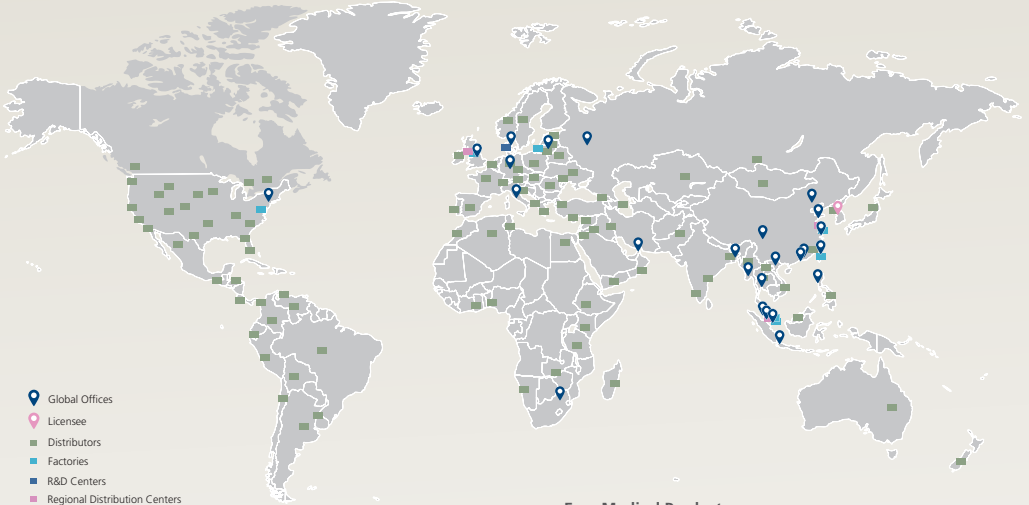

- Global Offices
- Licensee
- Distributors
- Factories
- R&D Centers
- Regional Distribution Centers



Esco Medical Products:

- MIRI® TL6 Time-Lapse Incubator
- MIRI® TL12 Time-Lapse Incubator
- MIRI® Multiroom Incubator
- MIRI® II-12 Multiroom Incubator
- Mini MIRI® Dry Incubator
- Mini MIRI® Humidity Incubator
- Esco Multi-Zone ART Workstation
- CelCulture® CO₂ Incubator
- MIRI® GA (Gas and Temperature Validation Unit)
- MIRI® AVT
- Versati™ Tabletop Centrifuge
- CultureCoin®

Infertility is a problem that has a significant social, psychological, and economic impact on afflicted individuals and couples. It is a global concern that knows no race or creed. It has been estimated that 1 in 6 couples struggle with infertility at least once in their lifetime.

Esco Medical is one of the divisions of the Esco Lifesciences Group. We provide innovative technological solutions for fertility clinics and laboratories. We aim to become the leading manufacturer of high-quality equipment such as long-term embryo incubators, ART workstations, anti-vibration tables, and time-lapse incubators.

Our products are designed with the Silent Embryo Hypothesis as a guiding principle. The Silent Embryo Hypothesis states that the less disturbed an embryo can remain, the better its developmental potential will be. Most of our products are designed in Denmark and made in the EU. Our primary focus is to increase pregnancy success rates and patient satisfaction.



21 Changi South Street 1 • Singapore 486 777
 Tel +65 6542 0833 • medical@escolifesciences.com
www.esco-medical.com

Esco Global Offices: Bangladesh | China | Denmark | Germany | Hong Kong | Indonesia | Lithuania | Malaysia | Myanmar | Philippines | Russia | Singapore | South Africa | South Korea | Taiwan | Thailand | UAE | UK | USA | Vietnam



Designed in Denmark

